

P/N: 64502-1101

Copyright

© 2014, FLIR Systems, Inc.

All rights reserved worldwide. Names and marks appearing herein are either registered trademarks or trademarks of FLIR Systems and/or its subsidiaries. All other trademarks, trade names or company names referenced herein are used for identification only and are the property of their respective owners.

Document identity

Publ. No.: 64502-1101
 Release: -
 Commit: 15419
 Language: en-US
 Modified: 2014-06-19
 Formatted: 2014-06-22

Corporate Headquarters

FLIR Systems, Inc.
 27700 SW Parkway Ave.
 Wilsonville, OR 97070
 USA
 Telephone: +1-503-498-3547

Website

<http://www.flir.com>

Customer support

<http://support.flir.com>

Disclaimer

Specifications subject to change without further notice. Camera models and accessories subject to regional market considerations. License procedures may apply. Products described herein may be subject to US Export Regulations. Please refer to exportquestions@flir.com with any questions.



General description	
The FLIR Exx-Series is a compact and rugged infrared camera that can be used in harsh environments while still providing you with the latest technology such as a modern touchscreen. The Exx-Series is the perfect choice when you are looking for a robust but feature-rich camera at an affordable price.	
Benefits:	
<ul style="list-style-type: none"> • Robust and sophisticated: The Exx-Series has a robust and light-weight design and can withstand a 2 meter drop. Big buttons combined with a modern touch screen and broad measuring capabilities, it is the right choice for demanding inspections in the field. • Best value for money: The FLIR Exx-Series combines good performance (up to 320 × 240 pixels), a user-friendly interface, and a rugged point-and-shoot design with an affordable price. 	
Imaging and optical data	
IR resolution	240 × 180 pixels
Thermal sensitivity/NETD	< 0.05°C @ +30°C (+86°F) / 50 mK
Field of view (FOV)	25° × 19°
Minimum focus distance	0.4 m (1.31 ft.)
Focal length	18 mm (0.7 in.)
Spatial resolution (IFOV)	1.82 mrad
F-number	1.3
Image frequency	60 Hz

P/N: 64502-1101

© 2014, FLIR Systems, Inc.

#64502-1101; r. -/15419; en-US

Imaging and optical data	
Focus	Manual
Digital zoom	2x and 4x
Panning	Panning over zoomed-in images
Detector data	
Detector type	Focal plane array (FPA), uncooled microbolometer
Spectral range	7.5–13 μm
Image presentation	
Display	Touch screen, 3.5 in. LCD, 320 × 240 pixels
Image adjustment	Auto or manual
Image presentation modes	
Image modes	IR image, visual image, MSX, picture in picture, thumbnail gallery
Picture in Picture	Scalable IR area on visual image
Measurement	
Object temperature range	–20°C to +120°C (–4°F to +248°F) 0°C to +650°C (+32°F to +1202°F)
Accuracy	±2°C (±3.6°F) or ±2% of reading, for ambient temperature 10°C to 35°C (+50°F to 95°F)
Measurement analysis	
Spotmeter	3
Area	3 boxes with max./min./average
Automatic hot/cold detection	Auto hot or cold spotmeter markers within area
Difference temperature	Delta temperature between measurement functions or reference temperature
Reference temperature	Manually set or captured from any measurement function
Emissivity correction	Variable from 0.01 to 1.0 or selected from materials list
External optics/windows correction	Automatic, based on inputs of optics/window transmission and temperature
Measurement corrections	Reflected temperature, optics transmission and atmospheric transmission
Set-up	
Color palettes	Arctic, Gray, Iron, Lava, Rainbow and Rainbow HC
Set-up commands	Local adaptation of units, language, date and time formats
Storage of images	
Image storage	Standard JPEG, including measurement data, on memory card
Image storage mode	Simultaneous storage of images in IR, visual and MSX

P/N: 64502-1101

© 2014, FLIR Systems, Inc.

#64502-1101; r. -/15419; en-US

Image annotations	
Text	Text from predefined list or soft keyboard on touch screen
Report generation	<ul style="list-style-type: none"> FLIR Tools software specifically designed to provide an easy way to create inspection reports. It is available on the major platforms – Android, Windows, MacOS and iOS.
Video recording in camera	
Non-radiometric IR-video recording	MPEG-4 to memory card
Video streaming	
Radiometric IR-video streaming	Full dynamic to PC using USB
Non-radiometric IR-video streaming	Uncompressed colorized video using USB
Digital camera	
Built-in digital camera	3.1 Mpixel (2048 × 1536 pixels), and one LED light
Digital camera, focus	Fixed focus
Built-in digital lens data	FOV 53° × 41°
Digital camera, aspect ratio	4:3
Laser pointer	
Laser	Activated by dedicated button
Laser alignment	Position is automatic displayed on the IR image
Laser classification	Class 2
Laser type	Semiconductor AlGaInP diode laser
Laser power	1 mW
Laser wavelength	635 nm (red)
Data communication interfaces	
SD Card	One card slot for removable SD memory cards
USB	
USB	<ul style="list-style-type: none"> USB-A: Connect external USB device USB Mini-B: Data transfer to and from PC / Uncompressed colorized video
USB, standard	USB Mini-B: 2.0
USB, connector type	<ul style="list-style-type: none"> USB-A connector USB Mini-B connector
Composite video	
Video out	Composite
Video, standard	CVBS (ITU-R-BT.470 PAL/SMPTE 170M NTSC)
Video, connector type	4-pole 3.5 mm jack
Power system	
Battery type	Rechargeable Li Ion battery
Battery voltage	3.7 V
Battery capacity	4.4 Ah, at +20°C to +25°C (+68°F to +77°F)
Battery operating time	Approx. 4 hours at +25°C (+77°F) ambient temperature and typical use

P/N: 64502-1101

© 2014, FLIR Systems, Inc.

#64502-1101; r. -/15419; en-US

Power system	
Charging system	In camera (AC adapter or 12 V from a vehicle) or 2-bay charger
Charging time	4 h to 90% capacity, charging status indicated by LED's
Charging temperature	0°C to +45°C (+32°F to +113°F)
Power management	Automatic shutdown and sleep mode (user selectable)
AC operation	AC adapter, 90–260 VAC input, 12 V output to camera
Start-up time from sleep mode	Instant on

Environmental data	
Operating temperature range	–15°C to +50°C (+5°F to +122°F)
Storage temperature range	–40°C to +70°C (–40°F to +158°F)
Humidity (operating and storage)	IEC 60068-2-30/24 h 95% relative humidity +25° C to +40°C (+77°F to +104°F) / 2 cycles
EMC	<ul style="list-style-type: none"> • EN 61000-6-2 (Immunity) • EN 61000-6-3 (Emission) • FCC 47 CFR Part 15 B (Emission)
Magnetic fields	EN 61 000-4-8, Test level 5 for continuous field (Severe industrial environment)
Encapsulation	IP 54 (IEC 60529)
Bump	25 g (IEC 60068-2-29)
Vibration	2 g (IEC 60068-2-6)
Safety	EN/UL/CSA/PSE 60950-1

Physical data	
Camera weight, incl. battery	0.880 kg (1.94 lb.)
Camera size (L x W x H)	246 x 97 x 184 mm (9.7 x 3.8 x 7.2 in.)
Tripod mounting	UNC ¼"-20 (adapter needed)
Material	Polycarbonate + acrylonitrile butadiene styrene (PC-ABS) Thixomold magnesium Thermoplastic elastomer (TPE)
Color	Graphite gray and black

Shipping information	
<ul style="list-style-type: none"> • Hard transport case • Infrared camera with lens • Battery • FLIR Tools download card • Handstrap • Memory card • Power supply, incl. multi-plugs • Printed documentation • USB cable • User documentation CD-ROM • Video cable 	
Packaging, weight	4.7 kg (10.36 lb.)
Packaging, size	500 x 350 x 190 mm (19.7 x 13.8 x 7.5 in.)
EAN-13	4743254001237
UPC-12	845188005269

P/N: 64502-1101

© 2014, FLIR Systems, Inc.

#64502-1101; r. -/15419; en-US

Supplies & accessories:

- T196961; IR lens, f = 30 mm, 15° incl. case
- T196960; IR lens, f = 10 mm, 45° incl. case
- T910814; Power supply, incl. multi plugs
- T911230ACC; Memory card SDHC 4 GB
- T910423; USB cable Std A <-> Mini-B
- T198509; Cigarette lighter adapter kit, 12 VDC, 1.2 m/3.9 ft.
- T910582ACC; Video cable
- T911093; Tool belt
- T198125; Battery charger, incl. power supply with multi plugs Exx
- T198113; IR lens, 76 mm (6°) with case and mounting support for Exx
- T198487; Li-Ion Battery pack 3.7V 17Wh
- T198484; Pouch for FLIR Exx series
- T198486; Tripod Adapter
- T198485; Sun shield
- T198341ACC; Transport case Exx
- T198586; FLIR Reporter Professional (license only)
- T198584; FLIR Tools
- T198583; FLIR Tools+ (license only)
- DSW-10000; FLIR IR Camera Player
- T127597L5; FLIR ResearchIR 3 (license only), 5 user licenses
- T127597L10; FLIR ResearchIR 3 (license only), 10 user licenses
- T127598L5; FLIR ResearchIR 3 Max (license only), 5 user licenses
- T127598L10; FLIR ResearchIR 3 Max (license only), 10 user licenses
- T198696; FLIR ResearchIR Max 4
- T198697; FLIR ResearchIR Max + HSDR 4
- T198579; FLIR ResearchIR 3 (CD)
- T198578; FLIR ResearchIR 3 (license only)
- T198575; FLIR ResearchIR 3 Max (CD)
- T198574; FLIR ResearchIR 3 Max (license only)
- T198292; Upgrade previous version to FLIR ResearchIR 3
- T198291; Upgrade previous version to FLIR ResearchIR 3 Max
- T198290; Upgrade FLIR ResearchIR 3 to FLIR ResearchIR 3 Max

Camera with built-in IR lens f=18 mm (25°)

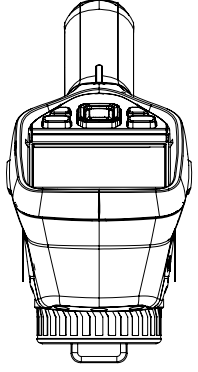
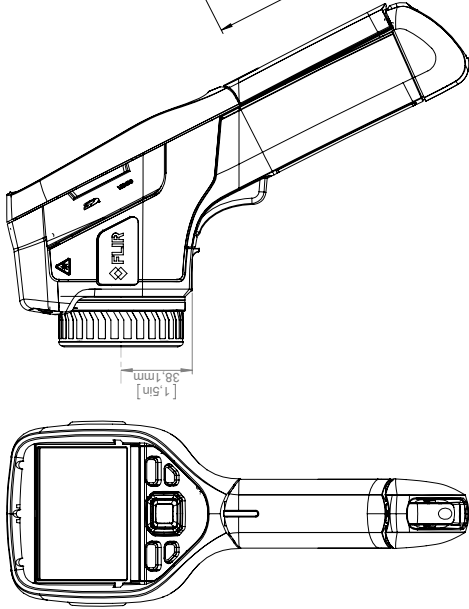
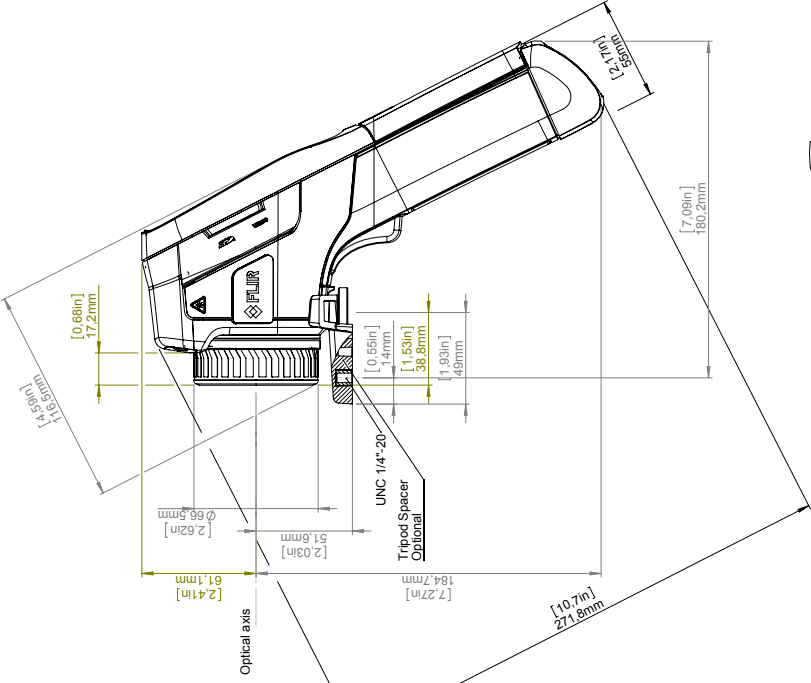
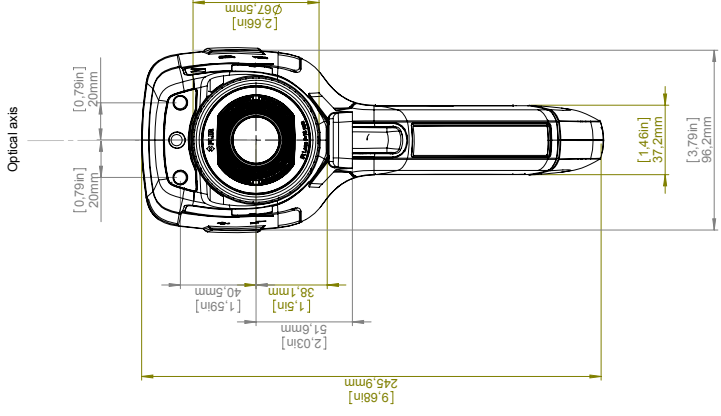
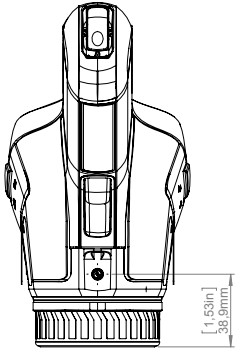
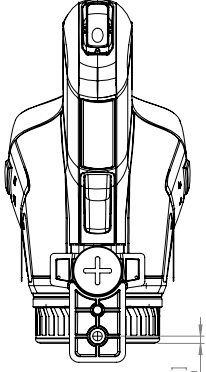
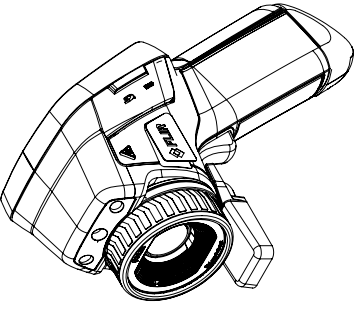

Model	2013-04-18	Check	CAHA	Drawn by	R&D Thermography	Size	A3	Sheet	1 of 4
Date	2013-04-18	Checked		Drawn		Scale	1:2	Sheet	FLIR
		Drawn		Drawn		Scale		Sheet	T1127869
		Drawn		Drawn		Scale		Sheet	SA
		Drawn		Drawn		Scale		Sheet	SA
		Drawn		Drawn		Scale		Sheet	SA
		Drawn		Drawn		Scale		Sheet	SA
		Drawn		Drawn		Scale		Sheet	SA
		Drawn		Drawn		Scale		Sheet	SA
		Drawn		Drawn		Scale		Sheet	SA
		Drawn		Drawn		Scale		Sheet	SA

Basic dimensions Flir Exx series

Camera with Lens IR f=10 mm (45°)

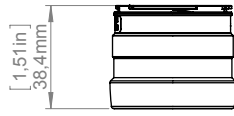
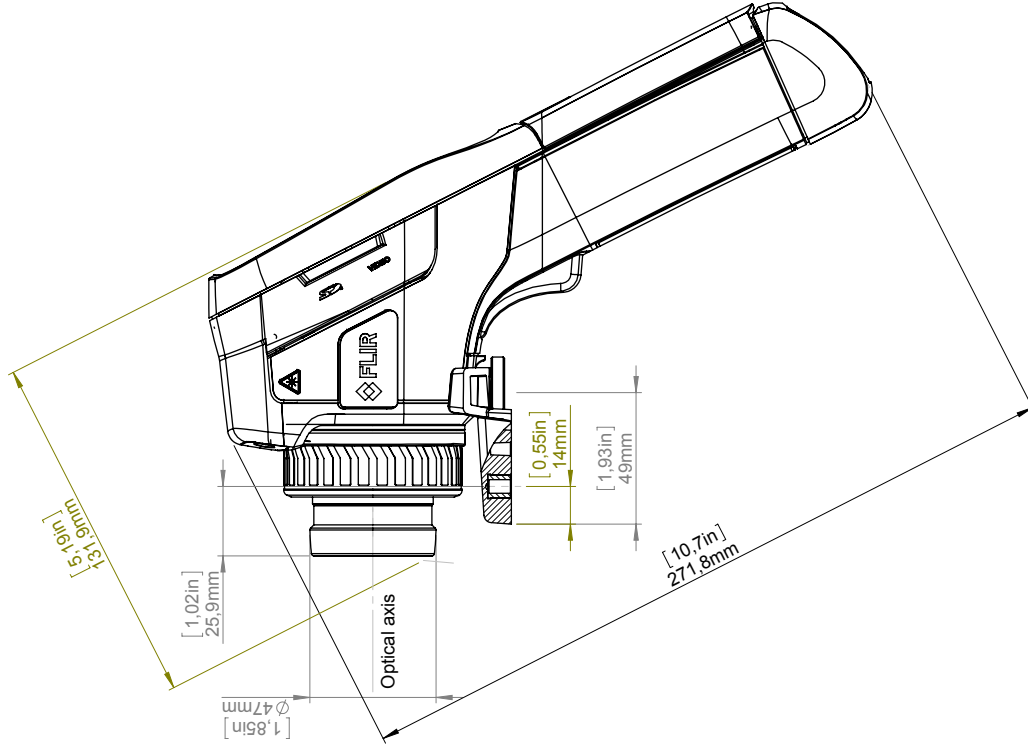
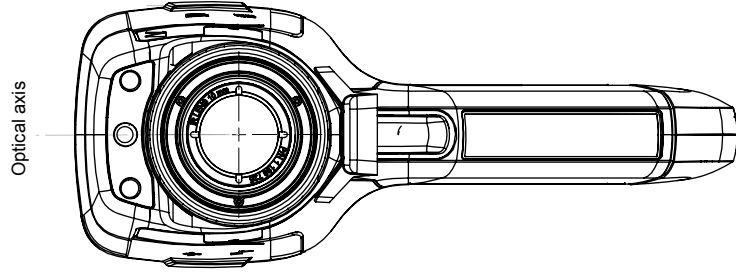
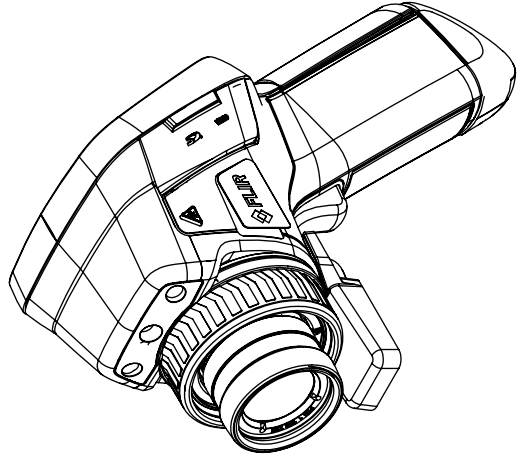

For additional dimensions see page 1

Modified	Check	Drawn by	Size	
2013-04-18	CAHA	R&D Thermography	A3	
Denomination			Scale 1:2 Sheet 2(4) Drawing No. T127869	
Basic dimensions Flir Exx series				

© 2012, FLIR Systems, Inc. All rights reserved worldwide. No part of this drawing may be reproduced, stored in a retrieval system, or transmitted in any form, or by any means, electronic, mechanical, photocopying, recording, or otherwise, without written permission from FLIR Systems, Inc. Specifications subject to change without further notice. Dimensional data is based on nominal values. Products may be subject to regional market considerations. License procedures may apply. Product may be subject to US Export Regulations. Please refer to exportquestions@flir.com with any questions. Diversion contrary to US law is prohibited.

Camera with Lens IR f=30 mm (15°)

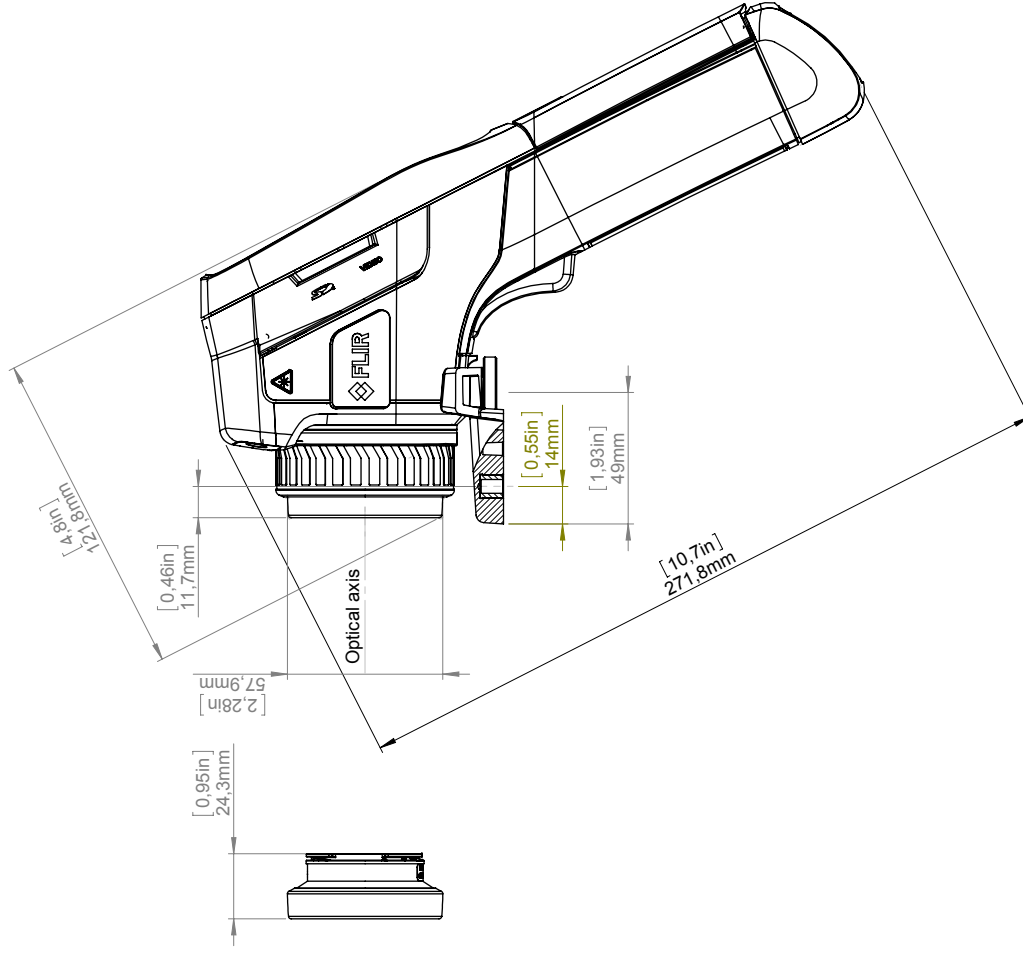
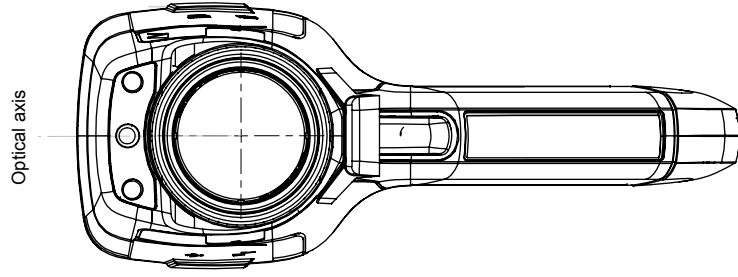
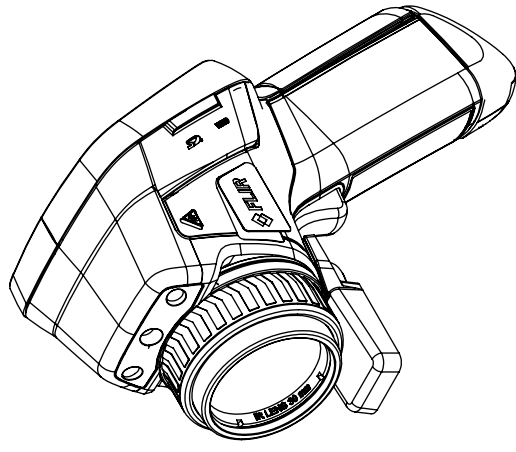

For additional dimensions see page 1

Modified 2013-04-18 Denomination	Check CAHA	Drawn by R&D Thermography	Size A3	Sheet 3(4)	Size A
Basic dimensions Flir Exx series			Scale 1:2	Drawing No. T127869	



© 2012, FLIR Systems, Inc. All rights reserved worldwide. No part of this drawing may be reproduced, stored in a retrieval system, or transmitted in any form, or by any means, electronic, mechanical, photocopying, recording, or otherwise, without written permission from FLIR Systems, Inc. Specifications subject to change without further notice. Dimensional data is based on nominal values. Products may be subject to regional market considerations. License procedures may apply. Product may be subject to US Export Regulations. Please refer to exportquestions@flir.com with any questions. Division contrary to US law is prohibited.

Camera with Lens IR f=76 mm (6°) incl support

© 2012, FLIR Systems, Inc. All rights reserved worldwide. No part of this drawing may be reproduced, stored in a retrieval system, or transmitted in any form, or by any means, electronic, mechanical, photocopying, recording, or otherwise, without written permission from FLIR Systems, Inc. Specifications subject to change without further notice. Dimensional data is based on nominal values. Products may be subject to regional market considerations. License procedures may apply. Product may be subject to US Export Regulations. Please refer to exportquestions@flir.com with any questions. Division contrary to US law is prohibited.

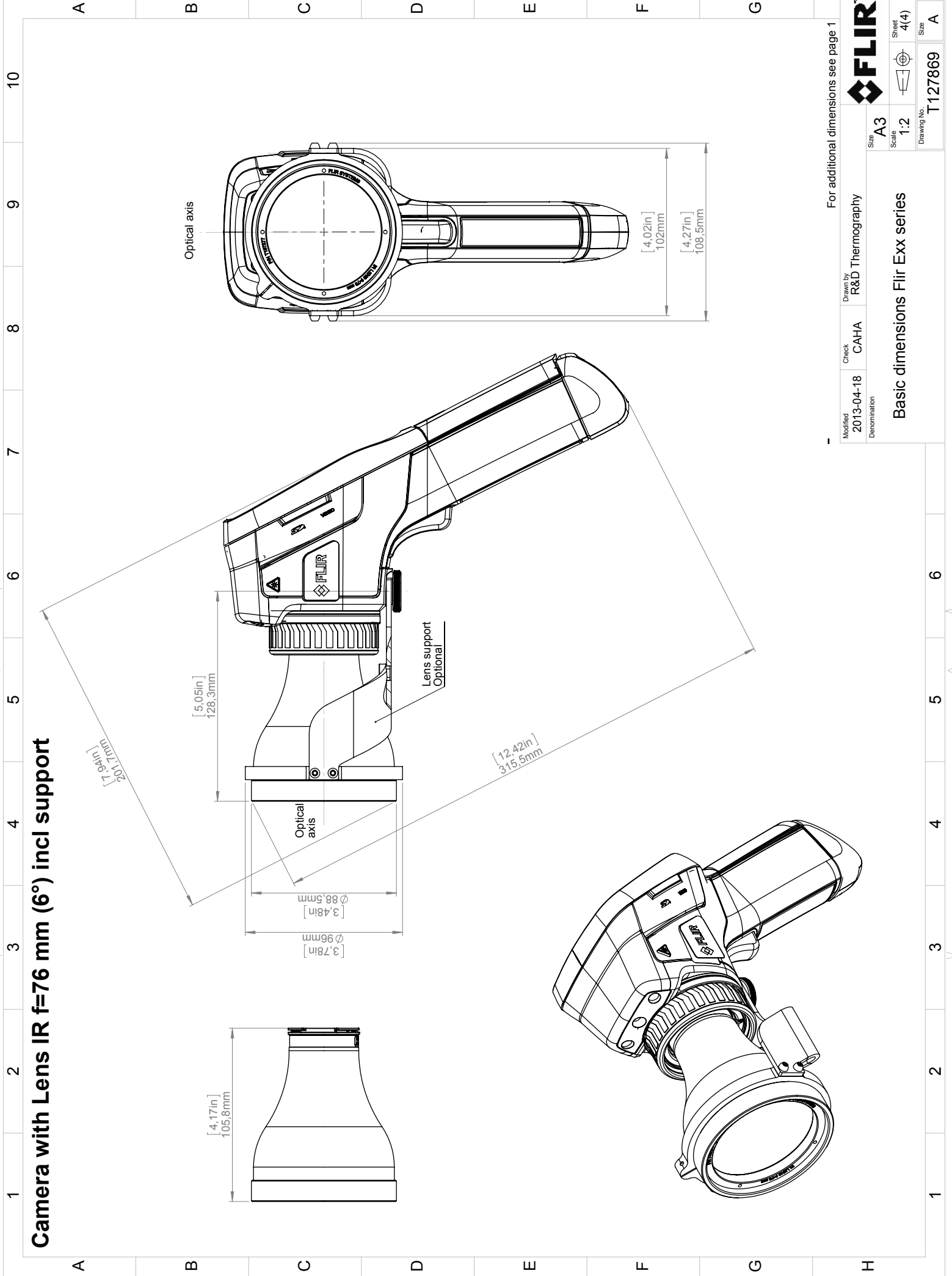

For additional dimensions see page 1

Modified	Check	Drawn by	Size			
2013-04-18	CAHA	R&D Thermography	A3			
Denomination		Basic dimensions Flir Exx series	Scale 1:2			